

# FIRE SAFETY HANDBOOK FOR AGRICULTURAL BUILDINGS



# Acknowledgments

Risk Management Association (RMA)

Minnesota Department of Labor and Industry

## References

MN Dept. of Public Safety - Minnesota State Fire Code  
(MSFC)

NFPA 30 - "Flammable and Combustible Liquids Code"

NFPA 37 - "Standard for Installation and Use of  
Stationary Combustion Engines and Gas  
Turbines"

NFPA 54 - "National Fuel Gas Code"

NFPA 58 - "Liquefied Petroleum Gas Code"

NFPA 70 - National Electrical Code

NFPA 110 - "Standard for Emergency and Stand-by  
Power Systems"

*(NFPA - National Fire Protection Association)*

## **Disclaimer**

The information and recommendations contained in this booklet have been obtained from sources which we believe to be competent, reliable, and tend to represent the best opinion on the subject. RAM Mutual Insurance does not make any warranty, guarantee, or representation as to whether or not any representation is absolutely correct or sufficient. No responsibility is assumed by RAM Mutual Insurance, and it cannot be assumed that all acceptable safety measures are listed in this booklet. Under particular circumstances or conditions, it may be that additional measures are required for fire safety.

“All rights reserved. No part of this booklet may be reproduced or reprinted without permission, in writing, from RAM Mutual Insurance, Esko, MN.”

Copyright 1988, 1998, 2002, 2006, 2019,2021

### **RAM Mutual Insurance**

P.O. Box 308

Esko, MN 55733

(800) 727-1315 ~ Member Services Department

[www.rammutual.com](http://www.rammutual.com)

Printed in U.S.A.

# INDEX

Begins  
on page

<b>Section A ~ Fire Extinguishers</b> .....	1
---	---

## **Section B ~ LP/Natural Gas Systems and Heating Equipment**

LP/Natural Gas System Requirements for Confinements.....	3
Gas Code Reference.....	5
Tank Placement.....	5

<b>Section C ~ Fuel and Gas Storage</b> .....	6
---	---

## **Section D ~ ASCE 7-16**

What is ASCE 7-16.....	9
Why Should We Consider ASCE 7-16.....	9
What Factors Determine Structural Integrity Standard .....	9
What is Needed to Receive the Reduced Rate .....	10

## **Section E ~ Building Materials**

Fire-Retardant/Flame-Retardant Building Materials .....	11
Non-Fire-Retardant Building Materials .....	12

## **Section F ~ Insulation and Thermal Barriers**

General Information.....	13
Polyurethane and Polystyrene Foam Insulation .....	14
Approved Thermal Barriers .....	14
Rigid Thermal Barriers.....	14
Spray Applied Thermal Barriers .....	15
Thermal Barrier vs. Ignition Barrier vs. Fire-Retardant Barriers .....	15
Cellulose/Wood Fiber Insulation .....	16

## **Section G ~ Electrical**

National Electrical Code (NEC) .....	17
Electrical Checklist/Common Hazards.....	17
Planning the System.....	17
General Installation.....	17
Wiring Devices.....	18
Lightning/Power Surge Protection .....	18
Lights.....	19
Motor/Controllers/Overcurrent Protection .....	20
Extension Cords .....	20
Electric Fence Chargers .....	21

**Section H ~ Generators**

Identifying Auto Generators ..... 23

**Section I ~ Liability**

Hand Rails ..... 24  
Debris and Clutter..... 24  
Loft Storage/Fall Hazard..... 24  
Dogs ..... 25  
Belt and PTO Shrouds..... 25  
No Trespassing/Warming Signs ..... 25

**Section J ~ Vegetation**

Exterior Vegetation Maintenance..... 26

**Section K ~ Farm Safety**

Grain..... 27  
Hogs ..... 27  
Dairy ..... 28  
Poultry ..... 28

**Section L ~ Fire Stop Requirement Options for  
Confinement Facilities with Connecting  
Hallways**

# Introduction

RAM Mutual provides this publication as an underwriting guide for agents, underwriters, loss control representatives, builders/contractors and farm owners. It contains safety and construction guidelines pertaining to agricultural operations. Where practical, this publication will reference applicable national codes and standards in addition to insurance underwriting requirements.

Farming is one of the most dangerous occupations worldwide. Injury and damage to your farm can be reduced by evaluating risks and minimizing them. Accidents can be prevented through better hazard recognition, well maintained equipment, having safety procedures in place, and training everyone about potential dangers.

## Common Hazards:

**Animals** – injuries inflicted by animals can include kicks, crushing, ramming and trampling.

**Chemicals** – pesticides and herbicides can cause injuries such as burns, respiratory illness or poisoning.

**Confined Spaces** – silos, water tanks and manure pits may contain unsafe atmospheres which can cause poisoning or suffocation.

**Electricity** – dangers include faulty switches, cords, machinery or overhead power lines.

**Heights** – falls from ladders, rooftops, silos and windmills are major causes of injury.

**Machinery** – hazards include tractors without roll-over protection structures (ROPS), power take-off (PTO) shafts, chainsaws, augers and machinery with unguarded moving parts.

## **Making Your Farm a Safer Workplace:**

Decisions are made daily related to a farming operation. Making your workplace safer creates a positive, safe environment for everyone. Some suggestions that you may want to incorporate in your routine to create a safe workplace include:

- ◆ Regularly walk around the farm and assess potential dangers.
- ◆ Make sure everyone working on the farm is properly educated on farm risks and trained in first aid.
- ◆ Keep all equipment in good repair.
- ◆ Store dangerous items, such as chemicals, behind locked doors and remove keys.
- ◆ Create a safety plan that includes ways to identify hazards and minimize potential risks.
- ◆ Always use appropriate safety equipment such as machinery guards and shields.

# SECTION A

## Fire Extinguishers

Fire extinguishers are required to be placed in all major buildings located near exits and high hazard areas. A 10-pound, dry-chemical, ABC-type extinguisher is required for use in all agricultural buildings and shops.



Large agricultural buildings require a 10-pound, ABC-type extinguisher every 150 feet. All motorized equipment, such as tractors and combines, require a fire extinguisher.

Fire extinguishers are to be checked annually (pressure gauge arrow in the green — SEE DIAGRAM) and filled or replaced immediately after use.



**CAUTION: After use, any remaining pressure will leak out in a very short time.**



- cloth
- wood
- rubber
- paper
- plastics
- gasoline
- grease
- oil
- electrical fires
- combustible metals
- kitchen fires

# SECTION B

## LP/Natural Gas Systems and Heating Equipment



**WARNING:** LP and natural gas systems require professional design, installation, and inspection. LP and natural gas-fired agricultural heating equipment is designed to operate on either low pressure (approximately .5 psi) or high pressure (1-10 psi). LP and natural gas-fired heaters burn gas vapor, not the liquid. First- and second-stage regulators control gas vapor pressure from the storage tank or pipeline to the heating equipment. LP gas installations require a first-stage regulator on the tank which reduces the pressure down to 8-10 psi. Second-stage regulators further reduce pressure to the operating limits of the low- and/or high-pressure gas heating equipment in use. In extremely cold climates, installations with very large demands will require multiple tanks or the use of a vaporizer to provide adequate gas vapor to fuel the heaters. Check with the manufacturers' specifications for proper cleaning and maintenance for the units.

## LP/Natural Gas System Requirements for Confinements

- ◆ LP storage tank spacing must comply with NFPA 58 - *Liquefied Petroleum Gas Code*.
- ◆ High-pressure gas lines are to be located **outside of buildings** and **buried underground**, to the extent practicable. Use copper pipe, black-coated steel pipe, or polyethylene pipe approved for the purpose and installed per code and manufacturers' instructions.
- ◆ Low-pressure regulators are typically located **outside of the building** and must be installed with the **vent facing down**. If regulators are located inside the buildings, vent lines are to be piped to the outside per code requirements. All pressure regulator vents must be located three feet from any opening into the building. Low-pressure regulators may be located inside buildings provided they comply with code and are properly installed.
- ◆ Hose-drop connections to brooders and space heaters require gas shut-off valves and sediment traps (drip leg). Gas hose must be identified with "LP Gas" or "LPG" stamped on the hose. ***Make certain that gas hoses do not come into contact with brooder canopies or the tops, sides, or heat discharge area of space heaters.*** Tie excess hose out of the way, as necessary. Gas hoses are not permitted to pass through partitions or building walls.
- ◆ Replace corroded piping with grounded stainless steel rigid pipe or flexible corrugated stainless steel gas tubing (CSST). Corrugated stainless steel gas tubing consists of a continuous, flexible, stainless steel pipe with an exterior PVC covering. Flexible gas piping is lightweight and requires fewer connections than traditional gas piping because it can be bent easily and routed around obstacles.

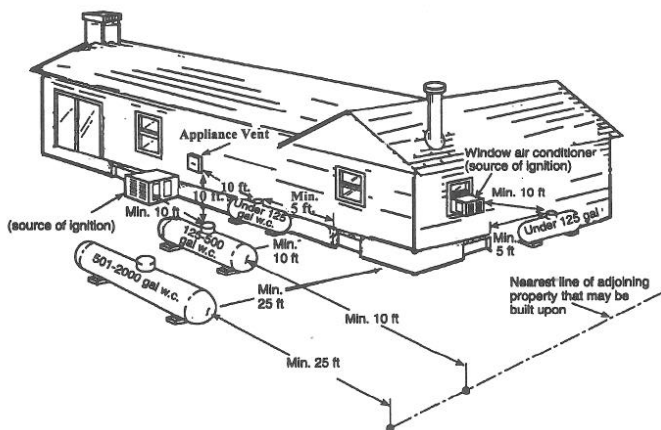

## LP GAS CONTAINER SPACING

**CAUTION:** All gas piping entering the barn through exterior walls (the first three feet) should be inspected annually for corrosion, which can result from condensation.

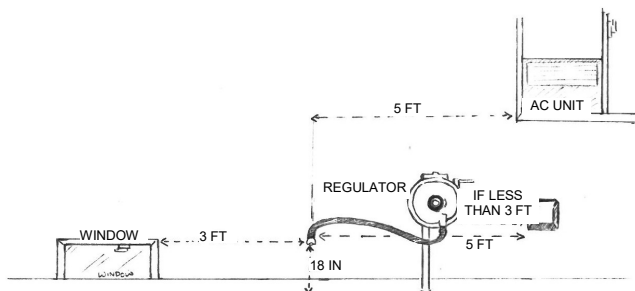

## LOW-PRESSURE (2ND-STAGE) LP GAS REGULATOR (LOCATED OUTSIDE OF BUILDING)

## Gas Code References

NFPA 54 - “National Fuel Gas Code” regulates the installation, operation, and maintenance of gas piping and gas equipment on the consumer’s premises.

NFPA 58 - “Liquefied Petroleum Gas Code” regulates the storage tank placement, piping, and regulator installation.

## Tank Placement

LP gas containers are to be installed outside of buildings and placed on masonry or noncombustible structural supports. Where physical damage from vehicles is a possibility, precautions are to be taken to protect against such damage. For container placement and spacing diagram. **Check with your insurance company for additional tank spacing requirements for high-value buildings and/or large confinement complexes.**

Table 6.3.1.1 Separation Distances Between Containers, Important Buildings, and Line of Adjoining Property That Can Be Built Upon

Water Capacity per Container		Minimum Distances							
		Mounded or Underground Containers <sup>a</sup>		Aboveground Containers		Between Containers <sup>b</sup>			
		gal	m <sup>3</sup>	ft	m	ft	m	ft	m
<125 <sup>c</sup>	<0.5 <sup>c</sup>	10	3	0 <sup>d</sup>	0 <sup>d</sup>	0	0		
125–250	0.5–1.0	10	3	10	3	0	0		
251–500	>1.0–1.9	10	3	10	3	3	1		
501–2,000	>1.9–7.6	10	3	25 <sup>c</sup>	7.6	3	1		
2,001–30,000	>7.6–114	50	15	50	15	5	1.5		
30,001–70,000	>114–265	50	15	75	23				
70,001–90,000	>265–341	50	15	100	30			¼ of sum of	
90,001–120,000	>341–454	50	15	125	38			diameters of	
120,001–200,000	>454–757	50	15	200	61			adjacent	
200,001–1,000,000	>757–3,785	50	15	300	91			containers	
>1,000,000	>3,785	50	15	400	122				

<sup>a</sup>See 6.3.2.1.

<sup>b</sup>See 6.3.4.5.

<sup>c</sup>See 6.3.4.4.

<sup>d</sup>See 6.3.4.1, 6.3.4.2, 6.3.4.3, and 6.3.4.4.

<sup>e</sup>See 6.3.1.3.

## Direct-Fired, Non-Vented Gas Heaters

Install in accordance with manufacturers' specifications. Do not install heaters on or near a combustible surface or shelf. Follow manufacturers' specifications for servicing and maintenance. Direct-fired, non-vented gas heaters require adequate, continuous airflow ventilation to displace combustion gases and prevent the depletion of oxygen in the space being heated.

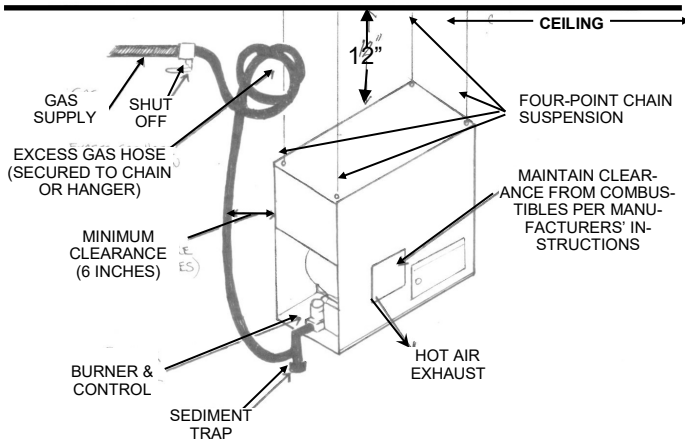

## DIRECT-FIRED, NON-VENTED GAS HEATERS

### Gas Brooder Stoves

Installation requires safety chains in addition to the brooder suspension system. Gas-fired brooders require frequent cleaning, close inspection, and periodic replacement of parts to operate safely. The entire heater, including pilots, burners, ceramic reflectors, and all other parts, should be examined before operation. Check for damaged parts, carbon build-up, and overall poor condition that would require replacement of parts or the entire heater. For fire insurance underwriting purposes, an annual gas system and heating equipment inspection is required to be performed by a qualified gas serviceman.

**WARNING:** Make certain that gas hoses do not come into contact with brooder canopies or the tops, sides, or heat discharge area of space heaters. Tie excess hose out of the way, as necessary.

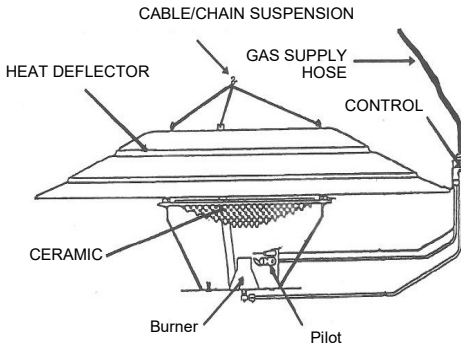

**GAS BROODER STOVE**

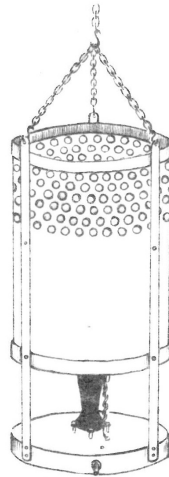

**UNIVERSAL GAS HEATER**

**NOTE:** A 24-hour-a-day fire watch is required in the building at the start-up of each new flock. This begins when the brooder heaters are lit and ends when the new birds have been in the building for 48 hours.

# SECTION C

## Fuel and Gas Storage

Improper storage, use, and handling of flammable and combustible liquids such as gasoline and diesel can result in fires or explosions. Accidental spills can also result in ground contamination. Guidelines that outline the proper storage use, and handling of flammable liquids such as gasoline and diesel fuel can be found in NFPA 30 – *Flammable and Combustible Liquids Code*.



Gasoline has a flash point at -45 degrees Fahrenheit. The flash point is the lowest temperature at which a flammable liquid gives off enough vapors to form an ignitable mixture with air. A fire or explosion will likely occur if exposed to a source of ignition. Diesel fuels typically have a flash point above 140 degrees Fahrenheit so they are not as easily ignitable but are still considered a fire hazard.

Above-ground gasoline and diesel fuel storage tanks must meet all of the requirements of the Minnesota State Fire Code (MSFC). Proper clearances must be observed with all above-ground storage tanks. Consult with your insurance company if you have questions regarding fuel storage. The following requirements apply to above-ground storage tanks.

- ◆ Storage tanks of 61 gallons and larger are to be at least **50 feet** from any building or structure. Locate tanks so that spillage will not flow toward or into buildings.
- ◆ Storage tanks are to be kept at least 20 feet from LP gas storage tanks and be set on a fire-resistant base of steel or masonry.
- ◆ Storage tanks containing a flammable or combustible liquid are to be marked with the name of the contents and with "*Flammable - Keep Fire and Flame Away*".
- ◆ Storage tank areas are to be kept free of weeds and combustible materials.
- ◆ Electrical dispensing pumps are to be permanently wired in accordance with the NEC using devices for explosion-proof wiring to fuel dispensing equipment. (*Refer to sketch.*)

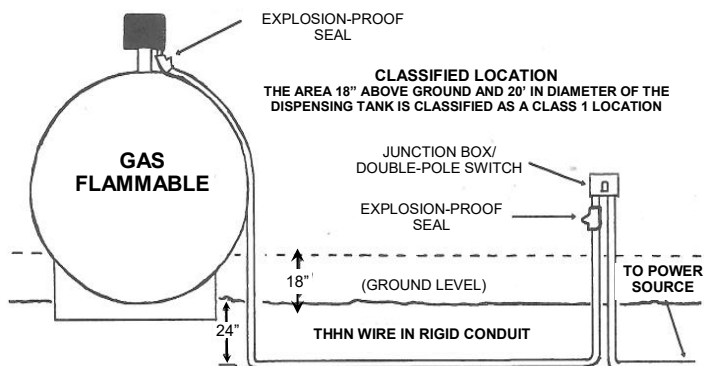

## National Electric Code: Wiring of Gas Dispensing Pumps

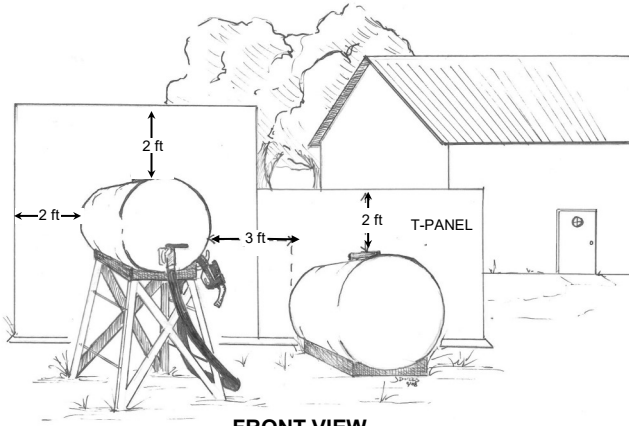

**FRONT VIEW  
WITH T-PANELS**

- ◆ Check with your insurance company regarding reduced clearance options for fuel and gas storage tanks using concrete T-panel fire barriers. (Refer to sketch.)

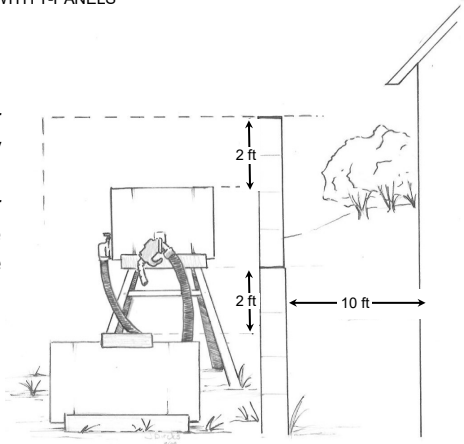

**SIDE VIEW  
WITH BLOCKS**

**CONCRETE T-PANEL OR BLOCK WALL (FILLED WITH CONCRETE)**

# SECTION D

## ASCE 7-22

RAM offers greatly reduced wind rates for new structures designed and constructed to meet or exceed the ASCE 7-22 structural integrity standard. ASCE 7-22 is the state's current adopted building code for residential and commercial buildings and is an integral part of the building codes of the United States. It is an essential standard every structural engineer needs in order to properly determine the various loads on a structure.

### **What is ASCE 7-22 Statute?**

A = American

S = Society

C = Civil

E = Engineers

7 = Chapter 7 from the 22 International Building Code (IBC)

### **Why Should We Consider ASCE 7-22?**

Industry standard to determine snow and wind loads on:

Residential (IRC),

Commercial (IBC), and

Ag Buildings (*currently exempt from the Minnesota State Building Code*)

### **What Factors Determine a Structural Integrity Standard?**

Factors included in the standard are local historical weather data, use of the building, dead and live load, roof slope, roof surface material, and heated or non-heated building.

## **What is Needed to Receive the Reduced Rate?**

A certified letter from the engineer is required specifying that the building meets or exceeds ASCE 7-22 standards, and must specifically show the applicant's name and building description.

Reduced rates are also available to existing structures providing they meet the current ASCE 7-22 structural integrity standard. If not, an engineering firm could assist you in bringing your building up to the current ASCE 07-22 standard.

**Please contact your agent or township mutual insurance company for additional assistance.**

# SECTION E

## Building Materials

This section specifies RAM's underwriting requirements for construction of agricultural buildings. Check with your local or state building and fire codes, as well as your insurance company, for guidelines and requirements prior to beginning construction.

### Fire-Retardant/Flame-Retardant Building Materials

- ◆ **Concrete or Masonry** are noncombustible and should be used whenever possible.
- ◆ **Gypsum Board (Sheetrock)** - There are three classifications of gypsum board: regular, type-X, and type-XP. Use type-X gypsum board wherever a fire-rated wall or ceiling is required. To achieve a one-hour fire rating, use a single layer of 5/8-inch type-X gypsum board on each side of the framing. Type-XP moisture-resistant gypsum board is available for use in high moisture areas.
- ◆ **Fire-Retardant Treated Plywood** has excellent fire-resistive properties and will withstand moisture in confinement buildings. The fire rating should be stamped on each sheet. A minimum of 1/2-inch fire-retardant-treated plywood is required.
- ◆ **Fiberglass-Reinforced Plastic (FRP) Panel/Class A** - Use fire-retardant FRP over plywood or Sheetrock where fire ratings are required.
- ◆ **Steel Sheets** are noncombustible and are used as exposed exterior and interior surfaces. Steel is classified as flame-retardant only as heat will transfer through rapidly when exposed to flame.

## Non-Fire Retardant Building Materials

- ◆ **Plywood, Chipboard (Wafer Board), Particleboard, and Oriented Strand Board (OSB)** - These products, while suitable for construction, are flammable due to the basic product contents and adhesives incorporated in them. Fire-retardant paint, when properly applied, is effective in reducing fire hazard characteristics of these products.
- ◆ **Fiberglass-Reinforced Plastic (FRP) Panel/Class C** - This product is used as an interior finish laminated to plywood or Sheetrock. **Class C FRP is highly flammable.**
- ◆ **High-Density Polyethylene (HDPE) Panel** - This product is used as an interior finish laminated to plywood or Sheetrock. This product is similar to FRP but without the fiberglass component. **HDPE panel is highly flammable.**

Firewall between garage and residence must be covered to roof sheathing with a minimum of 1/2" gypsum board on the garage side. If the garage ceiling has 5/8" gypsum, gable end of attic does not need to be covered.

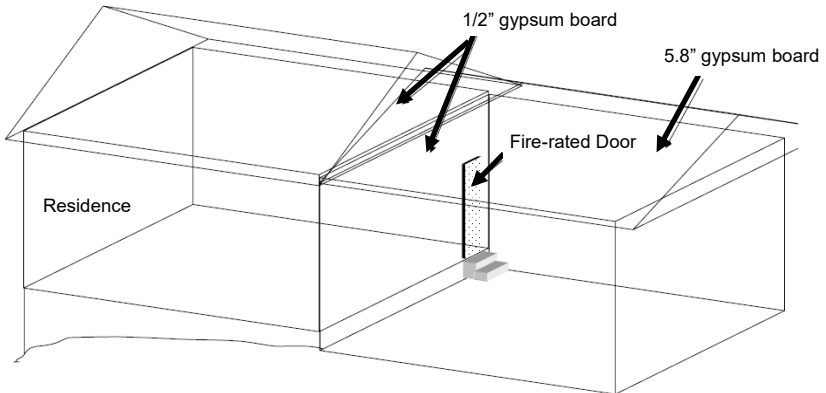

Requirement for Attached Garage

# SECTION F

## Insulation and Thermal Barriers

### General Information

Insulation in agricultural buildings may increase the fire risk and fire spread. All urethane insulation materials are considered combustible, producing toxic smoke and gases, and may contribute to the spread and intensity of the fire.

**The use of these materials, left exposed on the interior of buildings, is not acceptable for fire insurance underwriting purposes.** Choose an insulation product that is fire-resistant and suitable for an adverse interior environment.



Anytime you are dealing with insulation it is imperative to identify the manufacturers' installation requirements. This can be found on the Technical Data Sheet (TDS) or Product Data Sheet (PDS), and will indicate if the product requires a thermal barrier to be installed. If the product can not be identified, a thermal barrier is required.

## **Polyurethane and Polystyrene Foam Insulation**

- ◆ **Polyurethane Spray Applied (Thermal Barrier Required)** - This product is mixed and spray-applied on walls and ceilings at varying thicknesses.
- ◆ **Polyurethane/Polystyrene Rigid Foam Board (Thermal Barrier Required)** - A urethane or styrene rigid foam board with or without laminated vinyl, foil, or aluminum facers (also known as blue, gray, yellow, or pink insulation board).
- ◆ **Polystyrene Bead Board (Thermal Barrier Required)** - A molded-bead, cellular-plastic insulation board, white in color and without a facer.
- ◆ **Polyisocyanurate Expanding Foam Insulation (Thermal Barrier Required)** - Polyisocyanurate is applied by spraying liquid components into a wall or cavity. The product will be consumed by flame but will not contribute to fire spread.

### **Approved Thermal Barriers**

Most plastic insulation products must be protected with a thermal barrier to meet fire insurance underwriting requirements. The following thermal barriers will protect plastic insulation from igniting and will prevent rapid fire spread if properly installed and maintained.

#### **Rigid Thermal Barriers**

- ◆ 1/2-inch cement plaster;
- ◆ 1/2-inch fire-retardant treated plywood; and
- ◆ 1/2-inch type-X fire-rated gypsum board/drywall (5/8-inch type-X gypsum board is required for a one-hour fire wall).

***CAUTION: Just because a product is advertised as a thermal barrier does not mean that it has been approved by your insurance company for underwriting purposes. Ask for the technical data sheet, product data sheet or other written indications of acceptability.***

## **Spray Applied Thermal Barriers**

Contego International and DC315 (Brand Name) are single-component, water-based, acrylic latex coating. The product may be applied over combustible surfaces such as foam insulation, wood, or plastic interior surfaces. The product may be sprayed, brushed, or roller-applied to the required thickness per manufacturers' specifications.

Comparable products listed as thermal barriers by UL (Underwriters Laboratories), FM (Factory Mutual), or other recognized testing laboratories may be acceptable. Consult with your insurance company.

## **Thermal Barrier vs. Ignition Barrier vs. Fire-Retardant Coating**

**Thermal Barrier** - A thermal barrier is a thick material applied to the spray foam that slows down the rise of the temperature of the foam during a fire situation to delay or prevent the foams involvement in the fire. The thickness of the thermal barrier allows an escape time of 15 minutes for occupants.

**Ignition Barrier** - An ignition barrier is a thin, spray on or brush on coating that prevents the ignition of the product to which its applied from a spark or from direct heat but does not protect from direct flame over a period of time. Ignition barriers are applied to spray foam in spaces that are rarely accessed by people, such as attics or crawl spaces.

**Fire-Retardant Coating - Intumescent paints** - A brush or spray-on material that is applied to the surface of a building component or object to reduce combustibility or slow the spread of fire. Fire retardant substances can also be added to combustible materials to make them less combustible. **Fire retardant coatings are not approved for application over spray foam insulation.** (For example: spray retardant on a Christmas tree to prevent from burning.)

## Cellulose/Wood Fiber Insulation

- ◆ Cellulose/Wood Fiber is a pour- or blow-in insulation primarily for attics. This product should be considered combustible and requires a barrier, constructed of a rigid material, to maintain adequate clearances from chimneys, light fixtures, and other heat sources per manufacturer and building code requirements.
- ◆ Common areas of concern with blown in cellulose are around any appliance chimney, vent or flue pipe. Anytime cellulose is added in an attic space, an insulation shield should be in place. This device is installed around chimneys and keeps the cellulose a safe distance from the heat source. Every year many fires are caused by carelessness when adding cellulose to attics.



# SECTION G

## Electrical

### National Electrical Code (NEC)

The Minnesota Department of Labor and Industry provides a table of electrical wiring requirements for livestock and poultry confinement buildings based on the *National Electrical Code (NEC), Article 547 - Agricultural Buildings*. Refer to the full text of Article 547 as well as other applicable articles of the NEC for compliance.

### Electrical Checklist/Common Hazards

- ◆ Verify the electrical panel is fastened to the wall and the cover plate is secure to the panel.
- ◆ All breakers and replacement knockouts are in place.
- ◆ Junction boxes and electrical outlets have face plates.
- ◆ All lights have the proper protection or gasketed enclosures over the lamps.
- ◆ All electrical wiring is properly secured to interior surfaces.

### Planning the System

- ◆ Contact your power supplier concerning the distribution system to your farm or building.
- ◆ Contract a qualified, licensed electrical contractor to plan and install the electrical wiring in compliance with state code (all electrical work requires appropriate permits and inspections).

### General Installation

- ◆ Electrical wiring and devices installed in livestock and poultry buildings must be dust-tight, water-tight, and corrosion-resistant.

- All wiring is to be attached to the interior surfaces of the building and not concealed within walls, ceilings, ceiling cavities, or attic spaces.
- Electronic surge suppression devices are required in main and branch service panels to protect electrical devices, controllers, and microprocessors from lightning and power surge damage.

## Wiring Devices

- Electrical outlet, junction, switch, lighting fixture, and device boxes for use in confinement buildings are to be non-corrosive, dust-tight, and moisture-tight. Switch and receptacle outlet covers are to be gasketed.

GASKETED SPRING-LOADED COVERS

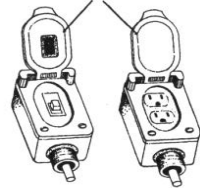

SWITCH RECEPTACLE

## Lightning/Power Surge Protection

- Surge suppression devices are required to be installed in the main electrical entrance service panel of all livestock and poultry confinement buildings.
- Surge suppression devices may also be installed in electrical subpanels for added protection.
- These devices are available through electrical contractors, lightning protection equipment suppliers, and installers.

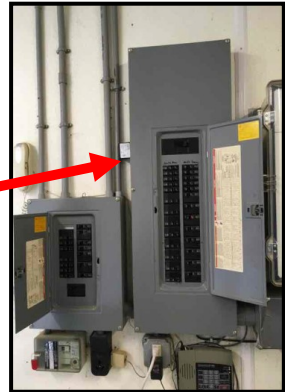

## Lights

Acceptable types of lighting for confinement buildings include LED, incandescent, fluorescent, and variations of high intensity discharge (HID) types. With few exceptions, light fixtures must be dust-resistant, corrosion-resistant, moisture-resistant, and equipped with heat-resistant globes to cover the lamps.

- ◆ **Incandescent** - Requires a globed, nonmetallic fixture rated for the wattage of bulb to be used. Lighting in poultry barns may allow the use of porcelain, keyless, incandescent fixtures with gasketed dust-tight and moisture-tight boxes, leaving the light bulb exposed.



**INCANDESCENT FIXTURE**  
(FOR WET LOCATIONS)



**INCANDESCENT FIXTURE  
PORCELAIN KEYLESS**  
(NON-SLOTTED)

- ◆ **LED** lighting is an energy-saving alternative to traditional incandescent bulbs. LED light bulbs can be used as replacement bulbs in most common light fixtures. LED lighting products produce light approximately 90% more efficiently than incandescent light bulbs.
- ◆ **Fluorescent** Fluorescent fixtures are required to be dust-tight, water-tight, and corrosion-resistant with gasketed enclosures over the lamps. (Single pin-type fluorescent fixtures may be acceptable for use in dairy stanchion-type barns. Check with your electrician and insurance company regarding this exception.)



**FLUORESCENT FIXTURE  
FOR DAMP BUILDINGS**

- ◆ **High Intensity Discharge (HID)** - This type of lighting is commonly used in poultry and dairy free-stall confinement buildings, and includes low- and high-pressure sodium and other similar types. HID lighting fixtures are required to withstand dust, moisture, and corrosive conditions found in confinement buildings.
- ◆ **Halogen Lighting (Portable)** - The use of portable halogen lights is not acceptable in agricultural confinement buildings. These lights operate at extremely high temperatures and are a potential fire hazard.

## **Motors/Controllers/Overcurrent Protection**

All electric motors located within the animal confinement area, within any feed processing room, or on any equipment where dust, moisture, or corrosion are present, are to be totally enclosed and appropriately rated.

**Motor and Appliance Connections** - All fixed electric motors and appliances are to be permanently wired in compliance with NEC. Cords or cables used to connect portable and permanent fan and feed system motors may incorporate twist-lock type connectors provided they comply with code.

## **Extension Cords**

- ◆ The use of extension cords is prohibited in agricultural confinement buildings for fire insurance underwriting purposes.
- ◆ For general use, extension cords should only be used as a “temporary source” of power.

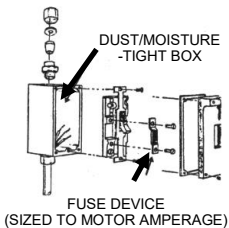

**COMBINATION ON-OFF SWITCH AND MOTOR PROTECTIVE DEVICE**

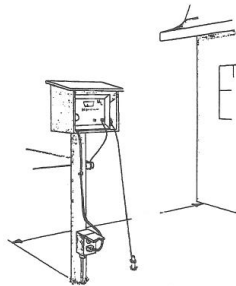

**OUTDOOR MOUNTED ELECTRIC FENCER**

## Electric Fence Chargers

- ◆ Lightning may strike pasture and yard fence wires and follow into buildings resulting in possible electrocution of livestock and/or a fire.
- ◆ Electric fence chargers are to be placed outside of and 10 feet away from buildings and hay storage areas.
- ◆ Do not run electric fence wire along buildings or hay storage areas.



# SECTION H

## Generators

Reference NFPA 37 and 110

Automatic standby generator exhaust is required to be vented through an approved wall pass-through. Follow manufacturers' and applicable code requirements. (*Refer to sketch below*)

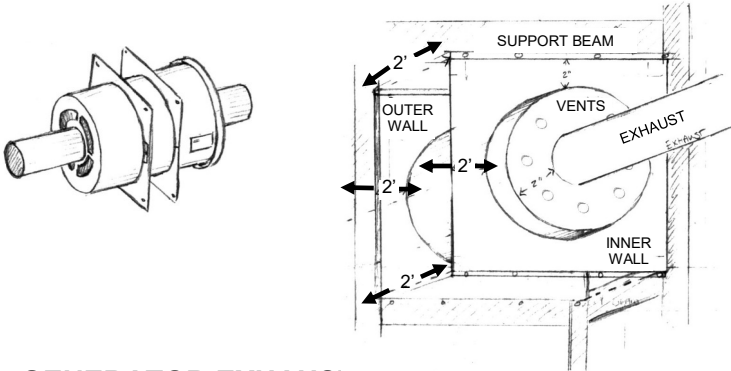

**GENERATOR EXHAUST WALL PASS-THROUGH**

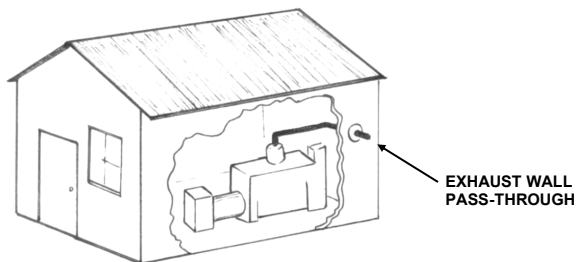

**SEPARATE BUILDING HOUSING STANDBY  
ELECTRIC GENERATOR**

# Identifying Auto Generators

The auto generator identification plate is located on the back of the generator. It is important to take a clear photo of the ID plate showing the serial number, model number and the specifications of the unit. The generator room should be clearly marked in confinement barns and generator sheds,

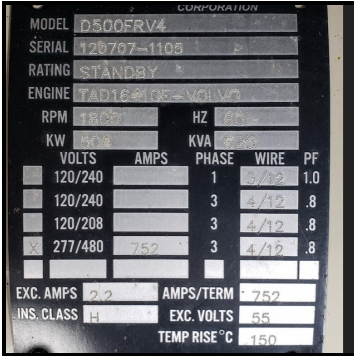

## Generator Information

### Diesel Generator



### LP Generator

# SECTION I

## Liability

### Hand Rails

- Railings are a critical safety feature on outdoor and indoor stairs and decks.
- Railings need to be installed on the deck/steps. Follow the requirements set by local and state laws.
- Railings need to be a minimum of 36" tall.
- Vertical members need to be no greater than 4" apart.

### Debris and Clutter

Farms should be kept clean and free of debris decreasing the liability exposures present on the farm premises.

### Loft Storage/Fall Hazard

Fixed ladders, floor hatches, and any open spaces used to access a storage area with a forklift must also be railed. A gate or removable railing with a top- and mid-rail must be used at any opening in the railing for a ladder, stairway or forklift/chain hoist access. A fixed railing with toe boards must be around all exposed sides of a ladder, stairway or floor hatch except at the entrance to the platform. Removable toe boards should be used for larger openings that may be used for forklift or chain hoist access if there is a risk of objects or materials falling from the storage area.

## Dogs

Dog owners are liable for injuries their pets cause. Contact your insurance company for a list of ineligible breeds.

## Belt and PTO Shrouds

Two of the most hazardous areas on your farm are the power takeoff shaft and electric motors. Without proper guards, shields, and constant operator awareness of the risks involved with operating this equipment, the spinning parts can quickly grab and entangle an unsuspecting farmer or family member.

Manufacturer installed guards must be replaced when removed for maintenance. These guards are designed to protect the operator and equipment. Guards not only reduce the risk of an injury, they also keep dust and other foreign objects from damaging gears and other moving parts.

## No Trespassing/Warning Signs

A **No Trespassing** sign will confirm the private ownership of your property. It is a safety pre-caution and can protect you against lawsuits. By posting the sign, you are saying that you have warned trespassers and are not responsible for their safety on your land. Trespassers do not have your permission to be on your property. Placing warning signs around livestock, slurry, overhead cables and bins/silos makes the farm a safer place to work.

# SECTION J

## Vegetation

### Exterior Vegetation Maintenance

- ◆ Vegetation should be maintained at a **minimum of 10 feet** around all buildings to prevent the spread of fires.
- ◆ The buildup of exterior vegetation on properties can be a prime ignition source for fire, especially if left untouched and not maintained.



- ◆ Overgrown vegetation around buildings can cause fire to spread into an area, between areas, a building or between buildings.



# SECTION K

## Farm Safety

With fire risks higher in rural areas, taking extra precautions ensures the safety of your livelihood.

### Grain

- ◆ Shields/guards on auger motors, grain handling equipment.
- ◆ Warning signs/locks on bin ladders/grain legs.
- ◆ PTO warnings where portable augers are used.
- ◆ Electrical panels— breakers & knockouts are in place.
- ◆ No extension cords.
- ◆ Exterior vegetation maintenance.

### Hogs

- ◆ Safety grates on pit and exhaust fans.
- ◆ CO2 monitors in generator and power washer rooms.
- ◆ CO2 monitors on coveralls when power washing barns.
- ◆ Clothes dryers should be properly vented.
- ◆ Electrical panels - breakers and knockouts are in place.
- ◆ Fans have protective shields/shrouds.
- ◆ All major appliances are plugged/hardwired directly into outlets.
- ◆ No extension cords.
- ◆ Exterior vegetation maintenance.
- ◆ Fire extinguishers.

## **Dairy**

- ◆ Clothes dryers must be properly vented.
- ◆ Electrical panels - breakers and knockouts are in place.
- ◆ Fans have protective shields/shrouds.
- ◆ All major appliances are plugged/hardwired directly into outlets.
- ◆ No extension cords.
- ◆ Exterior vegetation maintenance.
- Fire extinguishers.

## **Poultry**

- ◆ Clothes dryers must be properly vented.
- ◆ Electrical panels - breakers and knockouts are in place.
- ◆ Fans have protective shields/shrouds.
- ◆ All major appliances are plugged/hardwired directly into outlets.
- ◆ No extension cords.
- ◆ Exterior vegetation maintenance.
- ◆ Fire extinguishers.

# SECTION L

## **Fire Stop Requirement Options for Confinement Facilities with Connecting Hallways**

The diagrams on pages 30 thru 35 provide approved installations.

Contact your insurance company for additional information.

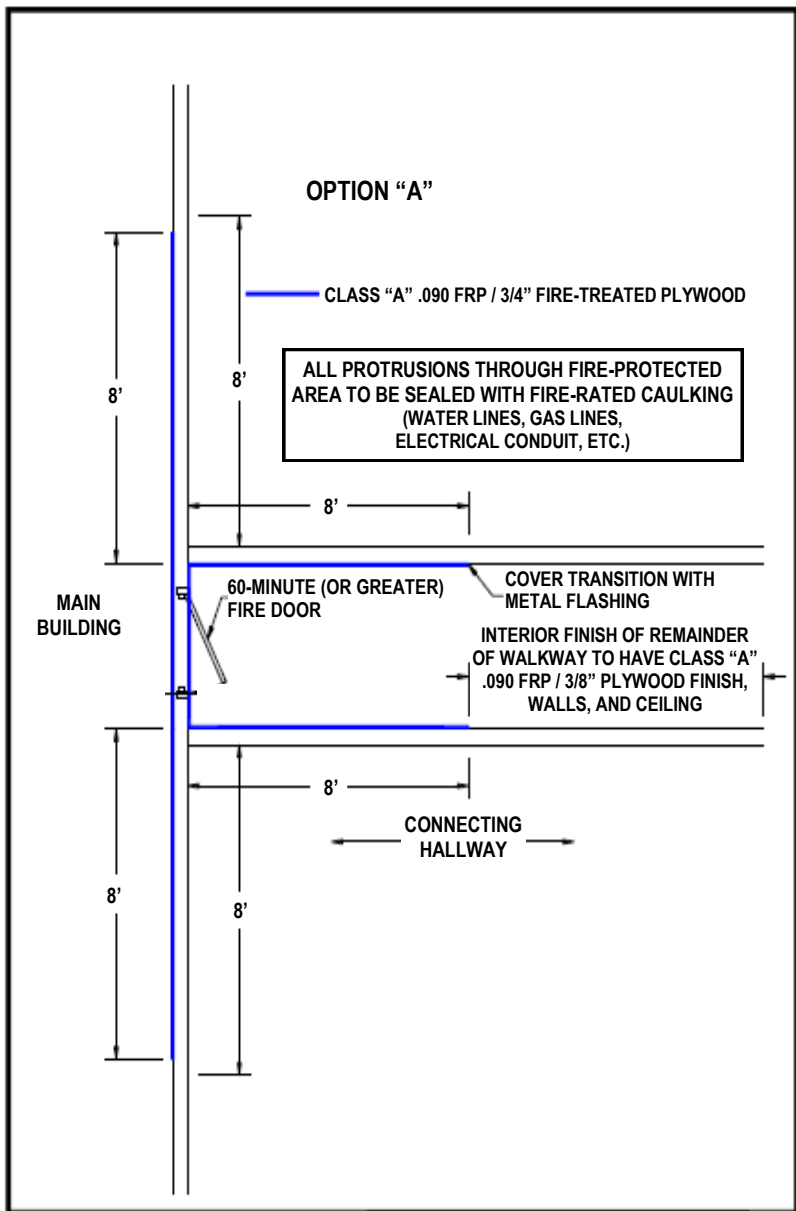

## OPTION "A" SECTION (WALKWAY TO FIT UNDER MAIN ROOF)

— 2 LAYERS 5/8" SHEETROCK IN ROOF SYSTEM  
EXTEND TO ROOF STEEL

— CLASS "A" .090 FRP / 3/4" FIRE-TREATED PLYWOOD

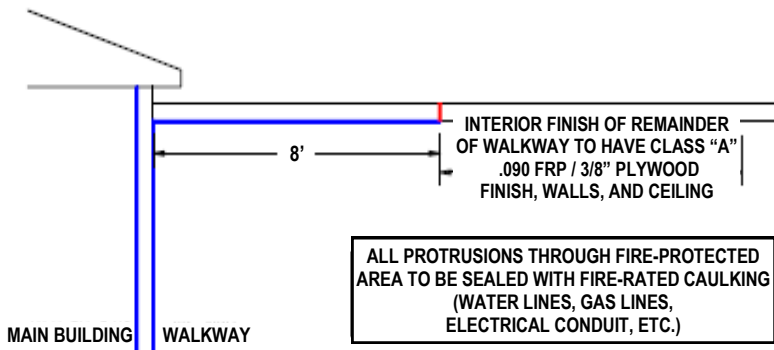

## OPTION "A2" SECTION (WALKWAY TO VALLEY INTO MAIN BUILDING)

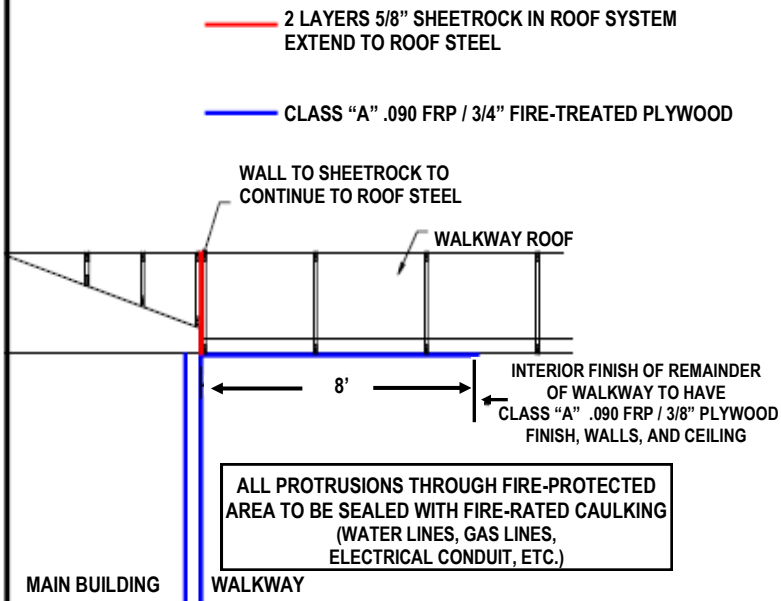

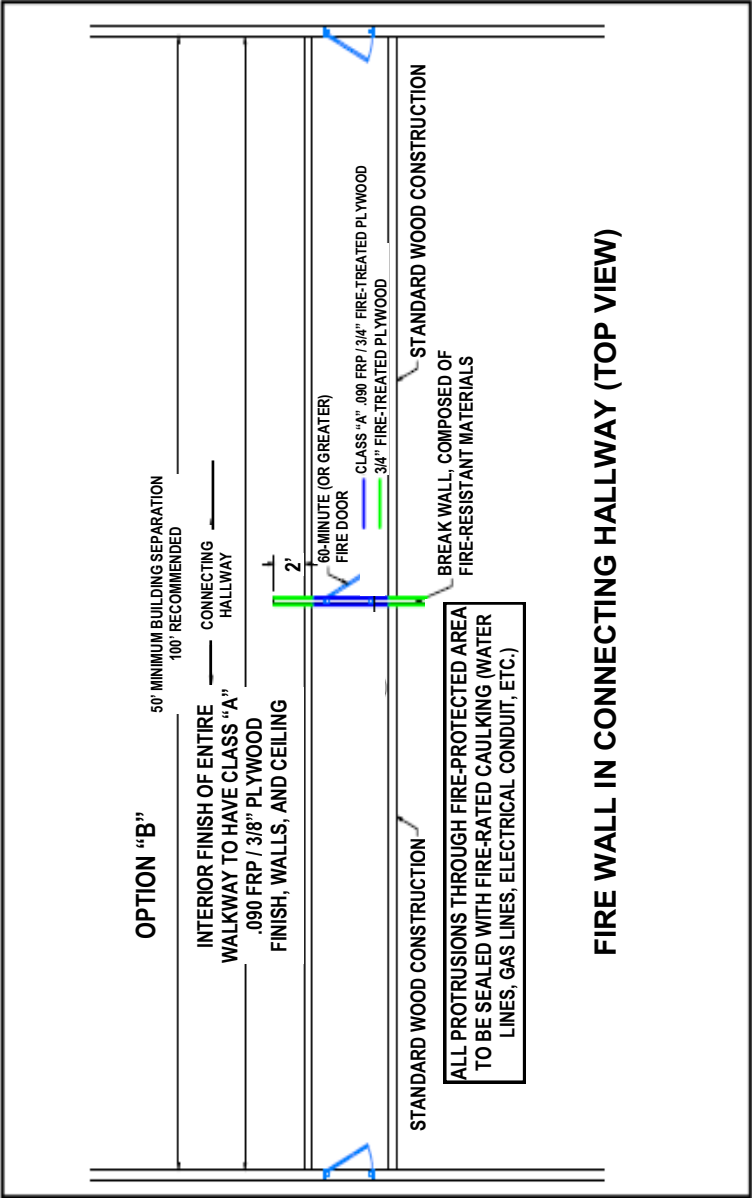

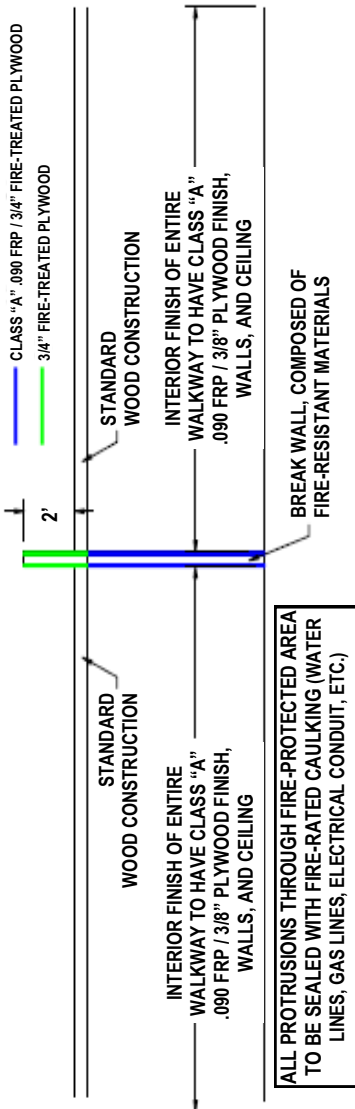

**FIRE WALL IN CONNECTING HALLWAY (SIDE VIEW)**

## OPTION "C" WITH GENERATOR

50' MINIMUM BUILDING SEPARATION  
100' RECOMMENDED

CONNECTING  
HALLWAY

INTERIOR FINISH OF ENTIRE WALKWAY  
TO HAVE CLASS "A" .090 FRP / 3/8"  
PLYWOOD FINISH, WALLS, AND CEILING

2'

60-MINUTE (OR GREATER)  
FIRE DOOR

GENERATOR DOOR MUST BE  
60-MINUTE (OR GREATER)  
FIRE DOOR

2'

60-MINUTE (OR GREATER)  
FIRE DOOR

STANDARD/  
WOOD CONSTRUCTION

BREAK WALL, COMPOSED OF  
FIRE-RESISTANT MATERIALS

WORKROOM INCLUDES  
UTILITY ROOM, PRESSURE  
WASHER, AND/OR SIMILAR  
EQUIPMENT

GENERATOR ROOM (INTERIOR  
OF GENERATOR ROOM MUST  
BE COVERED WITH 2 LAYERS  
5/8" SHEETROCK)

STANDARD  
WOOD CONSTRUCTION

BREAK WALL, COMPOSED OF  
FIRE-RESISTANT MATERIALS

2 LAYERS 5/8" SHEETROCK  
CLASS "A" .090 FRP / 3/4" FIRE-TREATED PLYWOOD  
3/4" FIRE-TREATED PLYWOOD

- NONCONNECTED GENERATOR BUILDING REQUIREMENTS:
1. IF COMBUSTIBLE CONSTRUCTION, BUILDING MUST BE AT LEAST 50' FROM ANY OTHER STRUCTURE.
  2. IF NONCOMBUSTIBLE CONSTRUCTION (BLOCK OR CONCRETE), BUILDING MUST BE AT LEAST 20' FROM ANY OTHER COMBUSTIBLE STRUCTURE.

ALL PROTRUSIONS THROUGH FIRE-PROTECTED AREA TO BE SEALED WITH FIRE-RATED CAULKING (WATER LINES, GAS LINES, ELECTRICAL CONDUIT, ETC.)

## **Disclaimer**

The information and recommendations contained in this booklet have been obtained from sources which we believe to be competent, reliable, and tend to represent the best opinion on the subject. RAM Mutual Insurance does not make any warranty, guarantee, or representation as to whether or not any representation is absolutely correct or sufficient. No responsibility is assumed by RAM Mutual Insurance, and it cannot be assumed that all acceptable safety measures are listed in this booklet. Under particular circumstances or conditions, it may be that additional measures are required for fire safety.

“All rights reserved. No part of this booklet may be reproduced or reprinted without permission, in writing, from RAM Mutual Insurance, Esko, MN.”

Copyright 1988, 1998, 2002, 2006, 2019,2021

### **RAM Mutual Insurance**

P.O. Box 308

Esko, MN 55733

(800) 727-1315 ~ Member Services Department

[www.rammutual.com](http://www.rammutual.com)

Printed in U.S.A.



**RAM MUTUAL  
INSURANCE**

P.O. Box 308  
Esko, Minnesota 55733